

Tankless Rack System with SENSEI™ CX Tankless Water Heaters

Wall Rack (TRW02 and TRW03 Models) Submittal Form



PROJECT DETAILS

Date: _____

Bid Date: _____

Project Name: _____

City / State / Zip Code: _____

Architect / Engineer: _____

Wholesaler / Contractor: _____

Model #: _____

Total System Btu/h: _____

Notes:

FEATURES AND BENEFITS

- Gas Type: Natural Gas (converts to Propane with parameter setting adjustment)
- Installation Type: Indoor (converts to outdoor installation with parameter setting adjustment and Versa-Vent™ outdoor vent cap) (sold separately)
- Ultra-efficient condensing technology
- Thermal Efficiency 97%
- Modulating technology with up to 318:1 turndown
- 15,000 Btu/h to 4.8 Million Btu/h
- 0.26 to 235 GPM (0.98 to 889.5 L/min) hot water flow range
- Ultra Low NOX - Complies with South Coast Air Quality Management
- District 14 ng/J or 20 ppm NOX emission levels
- Sealed combustion
- Venting options:
 - Common Vent System PPTI, 8 units up to 150 feet (46 m)
 - Concentric PPs - 150 ft (46 m) max vent length
 - Dual Pipe PPs - 150 ft (46 m) max vent length
 - PVC/CPVC - 2", 3", 4", 6"
- Primary and Secondary Stainless Steel Heat Exchanger
- Pre-assembled rack with CX199 indoor or outdoor tankless water heaters installed
- Powder coated black iron gas pipe and copper water manifolds
- Commercial controller available for hot water temperatures between 98°F and 185°F (37°C and 85°C)
- Flexible stainless steel pipe connections from hot and cold manifold/water heater connections
- Individual drain tee/drip leg on gas connection for each water heater
- Powder-coated steel frame for interior units; stainless steel frame for exterior units
- Isolation and pressure relief valves included and installed on each water heater

OPTIONS

Versa-Vent™ Outdoor Vent Cap (part # RXOVC)

Outdoor vent cap that converts an indoor tankless water heater (applicable models) to an outdoor installation.

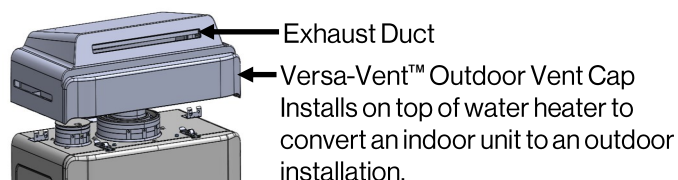

- The Rinnai EZConnect® and Cascade Cables electronically connect water heaters. This connection rotates water heater operation order to ensure equal usage among the entire system and enables all water heaters connected to modulate operation and function as one hot water source.
- The cables connect to the PC Board inside each water heater.

EZConnect® Cable

For rack configurations with **2 water heaters** only.

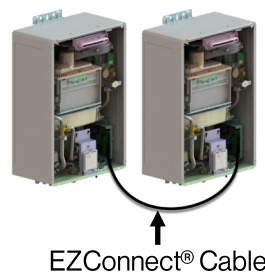

EZConnect® Cable

- Available Length: 6 ft (2 m)

Cascade Cable

For rack configurations with **2 through 24 water heaters**.

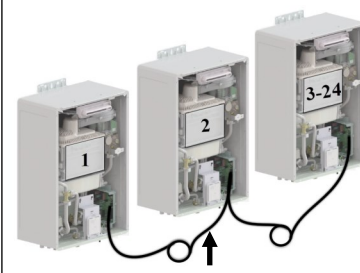

Cascade Cable

- Available Lengths: 10 ft or 26 ft (3 m or 8 m)
- One cable required for each water heater.

RACK SELECTION

2-UNIT RACK CONFIGURATIONS:

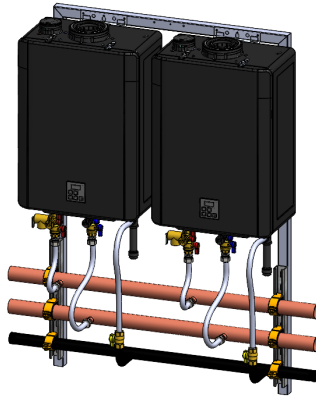
Item	Qty	Model Number ¹	Gas Type ²	Interior/ Exterior ³	Configuration	Illustration
		TRW02CXiN	Natural Gas or Propane	Interior or Exterior		

3-UNIT RACK CONFIGURATIONS:

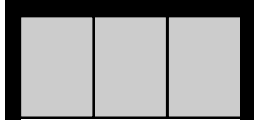
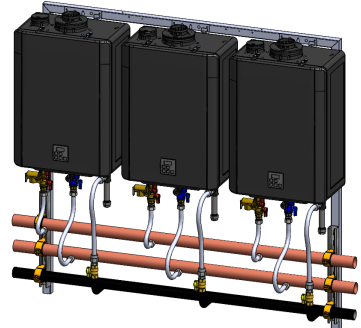
Item	Qty	Model Number ¹	Gas Type ²	Interior/ Exterior ³	Configuration	Illustration
		TRW03CXiN	Natural Gas or Propane	Interior or Exterior		

¹ For more information on model numbers, refer to the "Model Numbers Explained" section on the last page of this document.

² Water heater model (CX199i) factory default is Natural Gas, but converts to Propane with parameter setting adjustment.

³ Water heater model (CX199i) factory default is Indoor, but converts to an outdoor installation with parameter setting adjustment and the Versa-Vent™ outdoor vent cap (sold separately).

2-Unit Rack

Dimensions (2-Unit Rack)

Inches (mm)

Front

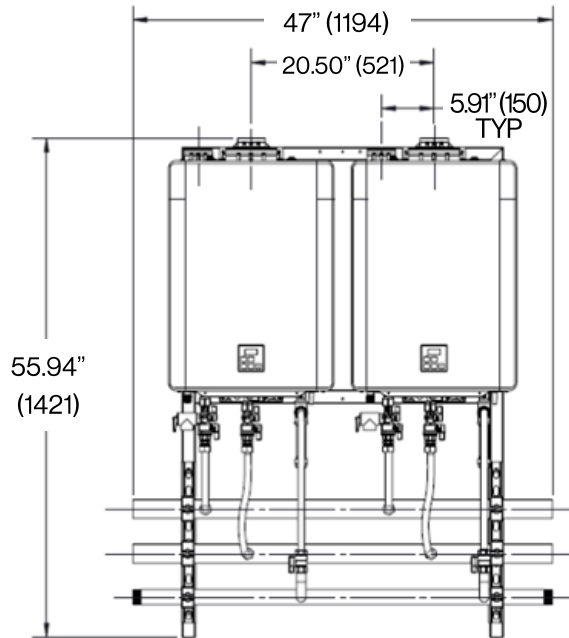

Back

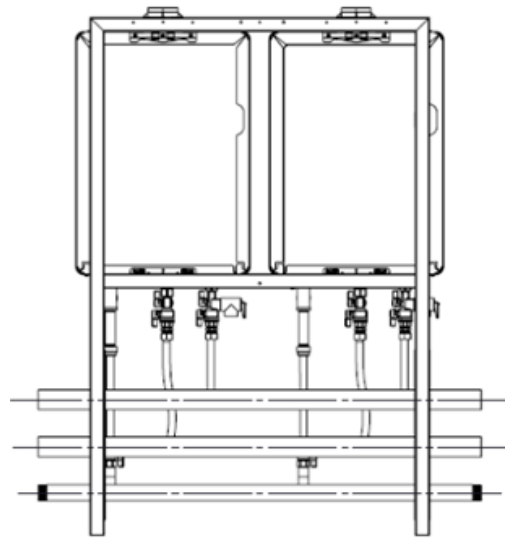

Left Side

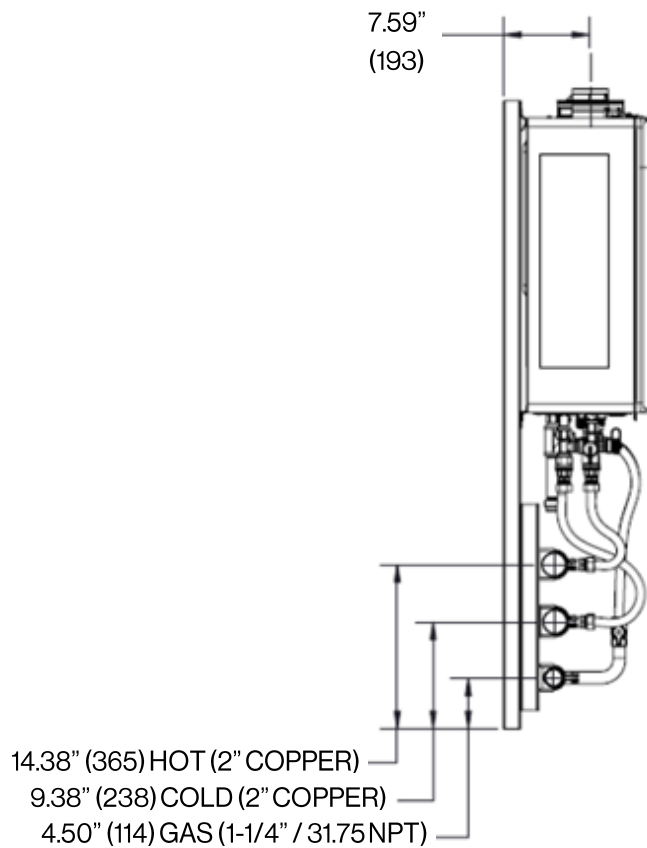

Bottom

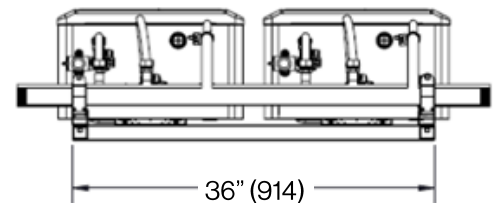

Specifications (2-Unit Rack)

Model	TRW02CXi
Water Heater Model	CX199i (NG/LP)
Crate Dimensions (HxLxD)	66" x 70" x 35" (167.64 cm x 177.8 cm x 89 cm)
Weight - Fully Assembled	153 lb (69.5 kg)
Weight - Shipping (total)	363 lb (165 kg)
Rack Frame - Specifications	
Frame Material	Aluminum
Frame Finish	Powder Coat
Color	Gray
Water & Gas Connections	
Hot Water Trunk Line Diameter	2" (51 mm)
Cold Water Trunk Line Diameter	2" (51 mm)
Hot Water Trunk Line Material	Rigid Copper
Cold Water Trunk Line Material	Rigid Copper
Water Trunk Connection Type	2" (51 mm) Pipe
Gas Trunk Line Diameter	1-1/4" (31.75 mm)
Gas Trunk Connection Type	1-1/4" (31.75 mm) MNPT
Gas Trunk Line Material	Schedule 40 Steel
Gas Branch Line Material	PVC Over CSST
Electric Requirements	
Voltage	AC 120 Volts - 60 Hz
Maximum Current (Amperes)	8
BTU and Flow Rates for CX199i (NG/LP)	
Number of Tankless Water Heaters	2
Flow rate @ 70°F (21°C) rise	10.8 GPM (40.9 L/min)
Flow rate @ 100°F (38°C) rise	7.6 GPM (28.8 L/min)
Minimum input rate (Btu/h)	15,200
Maximum input rate (Btu/h)	398,000

3-Unit Rack

Dimensions (3-Unit Rack)

Inches (mm)

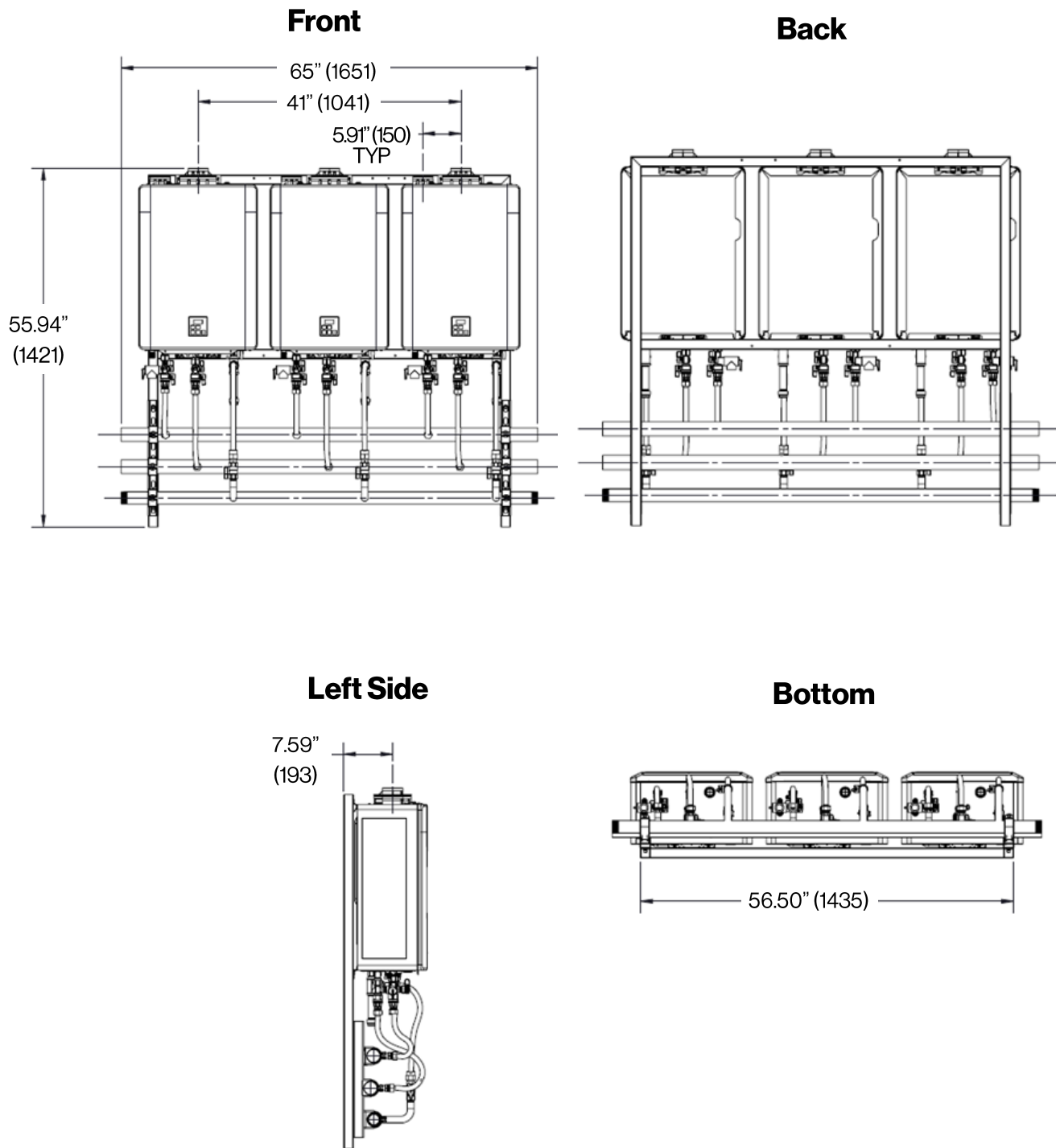

Specifications (3-Unit Rack)

Model	TRW03CXi
Water Heater Model	CX199i (NG/LP)
Crate Dimensions (HxLxD)	66" x 70" x 35" (167.64 cm x 177.8 cm x 89 cm)
Weight - Fully Assembled	228 lb (103.5 kg)
Weight - Shipping (total)	449 lb (204 kg)
Rack Frame - Specifications	
Frame Material	Aluminum
Frame Finish	Powder Coat
Color	Gray
Water & Gas Connections	
Hot Water Trunk Line Diameter	2" (51 mm)
Cold Water Trunk Line Diameter	2" (51 mm)
Hot Water Trunk Line Material	Rigid Copper
Cold Water Trunk Line Material	Rigid Copper
Water Trunk Connection Type	2" (51mm) PIPE
Gas Trunk Line Diameter	1-1/4" (31.75 mm)
Gas Trunk Connection Type	1-1/4" (31.75 mm) MNPT
Gas Trunk Line Material	Schedule 40 Steel
Gas Branch Line Material	PVC Over CSST
Electric Requirements	
Voltage	AC 120 Volts - 60 Hz
Maximum Current (Amperes)	12
BTU and Flow Rates for CX199i (NG/LP)	
Number of Tankless Water Heaters	3
Flow rate @ 70°F (21°C) rise	16.2 GPM (61 L/min)
Flow rate @ 100°F (38°C) rise	11.4 GPM (43 L/min)
Minimum input rate (Btu/h)	15,200
Maximum input rate (Btu/h)	597,000

PROJECT NOTES

MODEL NUMBERS EXPLAINED

TRS 02 CX i N	
TRS	System Type: TRS (Tankless Rack System)
04	Number of Water Heaters on Rack: 02, 03, 04, 05, 06
CX or CXP	Water Heater Model: <ul style="list-style-type: none">• CX (CX199)• CXP (CXP199) (includes built-in recirculation pump)
i	Installation Type: i (Interior) Converts to an outdoor installation with parameter setting adjustment and the Versa-Vent™ outdoor vent cap (sold separately).
N	Gas Type: N (Natural Gas) Converts to Propane with parameter setting adjustment.

CONTACT INFORMATION

Rinnai Commercial Water Heating Services

800-621-9419

commercialservices@rinnai.us

