

Tankless Rack System with SENSEI™ CX Tankless Water Heaters

Free-Standing Rack (Inline) Submittal Form



PROJECT DETAILS

Date: _____ Bid Date: _____

Project Name: _____

City / State / Zip Code: _____

Architect / Engineer: _____

Wholesaler / Contractor: _____

Model #: _____ Total System Btu/h: _____

Notes:

FEATURES AND BENEFITS

- Gas Type: Natural Gas (converts to Propane with parameter setting adjustment)
- Installation Type: Indoor (converts to outdoor installation with parameter setting adjustment and Versa-Vent™ outdoor vent cap) (sold separately)
- Ultra-efficient condensing technology
- Thermal Efficiency 97%
- Modulating technology with up to 318:1 turndown
- 15,000 Btu/h to 4.8 Million Btu/h
- 0.26 to 235 GPM (0.98 to 889.5 L/min) hot water flow range
- Ultra Low NOX - Complies with South Coast Air Quality Management
- District 14 ng/J or 20 ppm NOX emission levels
- Sealed combustion
- Venting options:
 - Common Vent System PPTl, 8 units up to 150 ft (46 m)
 - Concentric PPs - 150 ft (46 m) max vent length
 - Dual Pipe PPs - 150 ft (46 m) max vent length
 - PVC/CPVC - 2", 3", 4", 6"
- Primary and Secondary Stainless Steel Heat Exchanger
- Pre-assembled rack with CX199 indoor or outdoor tankless water heaters installed
- Wall-mount or free-standing/floor mount options
- Powder coated black iron gas pipe and copper water manifolds
- Commercial controller available for hot water temperatures between 98°F and 185°F (37°C and 85°C)
- Flexible stainless steel pipe connections from hot and cold manifold/water heater connections
- Individual drain tee/drip leg on gas connection for each water heater
- Marine grade powdered coated aluminum frame
- TRS fits through standard 32" (813 mm) doorway
- Lifting eyebolts on free-standing racks
- Isolation and pressure relief valves included and installed on each water heater

OPTIONS

Versa-Vent™ Outdoor Vent Cap (part # RXOVC)

Outdoor vent cap that converts an indoor tankless water heater (applicable models) to an outdoor installation.

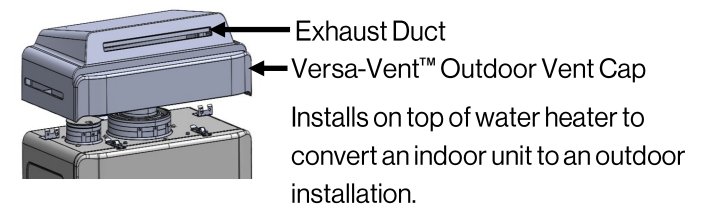

Electronic Connection Cable (select cable type below)

- The Rinnai EZConnect® and Cascade Cables electronically connect water heaters. This connection rotates water heater operation order to ensure equal usage among the entire system and enables all water heaters connected to modulate operation and function as one hot water source.
- The cables connect to the PC Board inside each water heater.

EZConnect® Cable

For rack configurations with **2 water heaters** only.

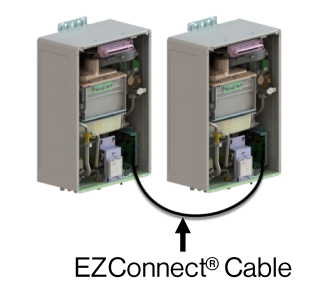

– Available Length: 6 ft (2m)

Cascade Cable

For rack configurations with **2 through 24 water heaters**.

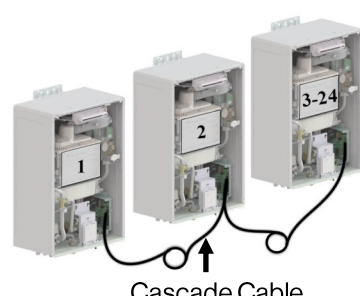

– Available Lengths: 10 ft or 26 ft (3 m or 8 m)
 – One cable required for each water heater.

RACK SELECTION

2-UNIT RACK CONFIGURATIONS:

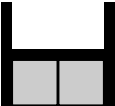
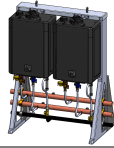
Item	Qty	Model Number ¹	Gas Type ²	Interior/ Exterior ³	Configuration	Illustration
		TRS02ILCXiN	Natural Gas or Propane	Interior or Exterior		

3-UNIT RACK CONFIGURATIONS:

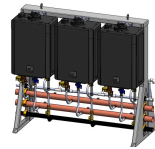
Item	Qty	Model Number ¹	Gas Type ²	Interior/ Exterior ³	Configuration	Illustration
		TRS03ILCXiN	Natural Gas or Propane	Interior or Exterior		

¹ Model Numbers Explained:

TRS 02 CX i N	
TRS	System Type: TRS (Tankless Rack System)
04	Number of Water Heaters on Rack: 02, 03, 04, 05, 06
CX or CXP	Water Heater Model: <ul style="list-style-type: none"> • CX (CX199) • CXP (CXP199) (includes built-in recirculation pump)
i	Installation Type: i (Interior) Converts to an outdoor installation with parameter setting adjustment and the Versa-Vent™ outdoor vent cap (sold separately).
N	Gas Type: N (Natural Gas) Converts to Propane with parameter setting adjustment.

² Water heater model (CX199i) factory default is Natural Gas, but converts to Propane with parameter setting adjustment.

³ Water heater model (CX199i) factory default is Indoor, but converts to an outdoor installation with parameter setting adjustment and the Versa-Vent™ outdoor vent cap (sold separately).

2-Unit Free-Standing Frame

Inches (mm)

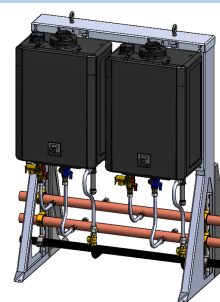

Front

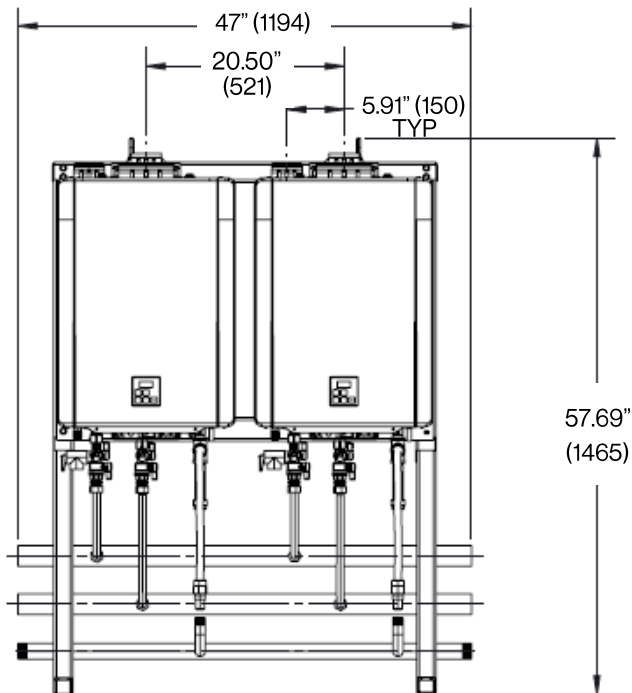

Left Side

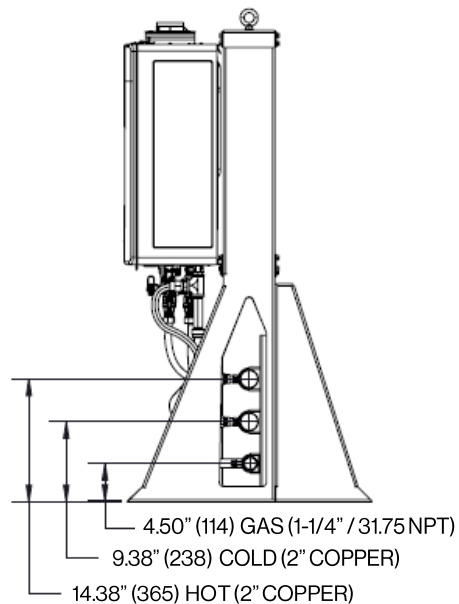

Bottom

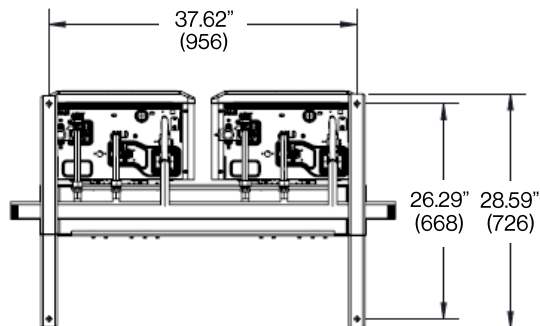

Configurations:

Model	Configuration	Illustration
TRS02ILCX	Inline Facing Same Direction 2-Units	

Model:	TRS02ILCX
Water Heater Model	CX199i (NG/LP)
TRS Dimensions (HxLxD)	57.69" x 47" x 28.59" / 146.53 cm x 119 cm x 72.61 cm (see "Technical Specifications" section for additional dimensions)
Crate Dimensions (HxLxD)	66" x 70" x 35" (167.64 cm x 177.8 cm x 89 cm)
Weight - Fully Assembled	214 lb (97 kg)
Weight - Shipping (total)	416 lb (188.7 kg)
Rack Frame - Specifications	
Frame Rail Type	Sheet Metal
Frame Material	Aluminum (0.090 5052-H32)
Frame Finish	Powder Coat
Color	Gray
Water & Gas Connections	
Hot Water Trunk Line Diameter	2" (51mm)
Cold Water Trunk Line Diameter	2" (51mm)
Hot Water Trunk Line Material	Rigid Copper
Cold Water Trunk Line Material	Rigid Copper
Water Trunk Connection Type	2" (51mm) PIPE
Gas Trunk Line Diameter	1-1/4" (31.75 mm)
Gas Trunk Connection Type	1-1/4" (31.75 mm) MNPT
Gas Trunk Line Material	Schedule 40 Steel
Gas Trunk Branch Line Material	PVC Over CSST
Condensate Trunk Line Diameter	3/4" (19 mm)
Condensate Trunk Material	Schedule -40 PVC
Condensate Trunk Connection Type	3/4" (19 mm) Pipe
Electric Requirements	
Prewired Electrical Assembly	Not Applicable
Voltage	AC 120 Volts - 60 Hz
Maximum Current (Amperes)	8
BTU and Flow Rates for CX199i (NG/LP)	
Number of Tankless Water Heaters	2
Flow Rate @ 70°F (21°C) rise	10.8 GPM (40.88 L/min)
Flow Rate @ 100°F (38°C) rise	7.6 GPM (28.76 L/min)
Minimum Input Rate (Btu/h)	15,200
Maximum Input Rate (Btu/h)	398,000

TRS02ILCX

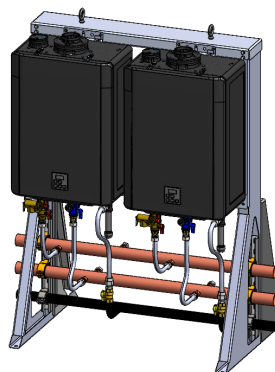

3-Unit Free-Standing Frame

Inches (mm)

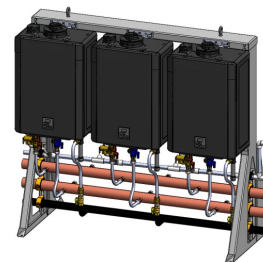

Front

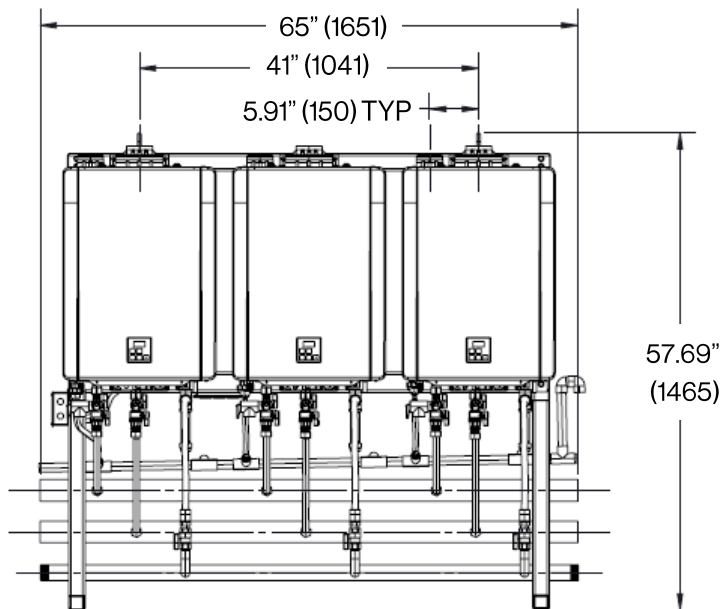

Left Side

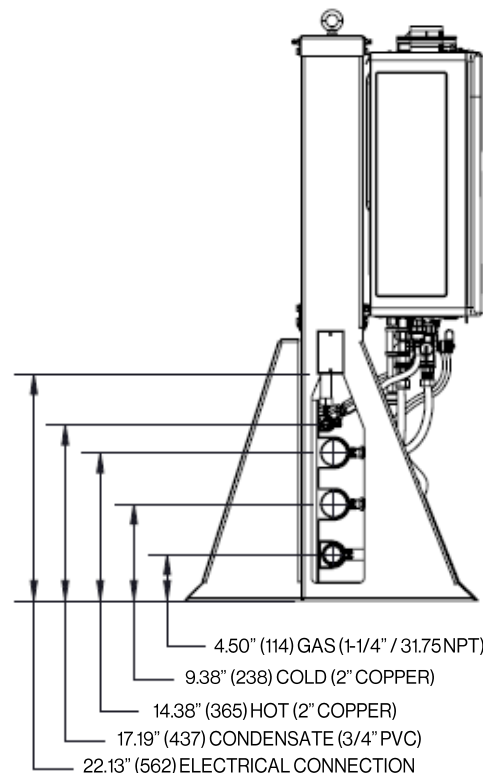

Bottom

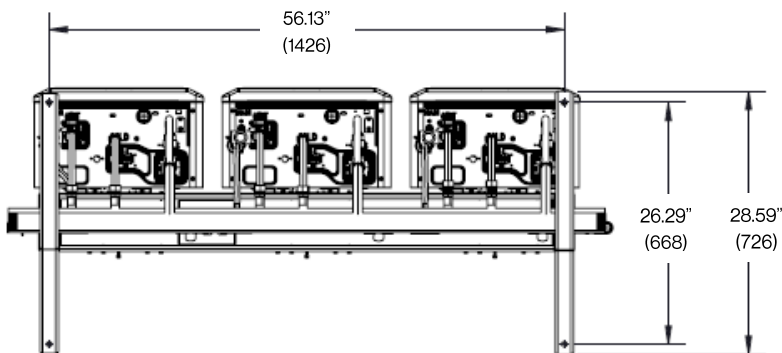

Configurations:

Model	Configuration	Illustration
TRS03ILCX	<p>3-Units</p>	

Model:	TRS03ILCX
Water Heater Model	CX199i (NG/LP)
TRS Dimensions (HxLxD)	57.69" x 65" x 28.59" / 146.53 cm x 165 cm x 72.61 cm (see "Technical Specifications" section for additional dimensions)
Crate Dimensions (HxLxD)	66" x 70" x 35" (167.64 cm x 177.8 cm x 89 cm)
Weight - Fully Assembled	315 lb (142.9 kg)
Weight - Shipping (total)	512 lb (232.5 kg)
Rack Frame - Specifications	
Frame Rail Type	Sheet Metal
Frame Material	Aluminum (0.090 5052-H32)
Frame Finish	Powder Coat
Color	Gray
Water & Gas Connections	
Hot Water Trunk Line Diameter	2" (51mm)
Cold Water Trunk Line Diameter	2" (51mm)
Hot Water Trunk Line Material	Rigid Copper
Cold Water Trunk Line Material	Rigid Copper
Water Trunk Connection Type	2" (51mm) PIPE
Gas Trunk Line Diameter	1-1/4" (31.75 mm)
Gas Trunk Connection Type	1-1/4" (31.75 mm) MNPT
Gas Trunk Line Material	Schedule 40 Steel
Gas Branch Line Material	PVC Over CSST
Condensate Trunk Line Diameter	3/4" (19 mm)
Condensate Trunk Line Material	Schedule-40 PVC
Condensate Trunk Connection Type	3/4" (19 mm) Pipe
Electric Requirements	
Prewired Electrical Assembly	Yes (Indoor Models Only)
Voltage	AC 120 Volts - 60 Hz
Max Current (Amperes)	12
BTU and Flow Rates for CX199i (NG/LP)	
Number of Tankless Water Heaters	4
Flow rate @ 70°F (21°C) rise	21.6 GPM (81.76 L/min)
Flow rate @ 100°F (38°C) rise	15.1 GPM (57.5 L/min)
Minimum input rate (Btu/h)	15,200
Maximum input rate (Btu/h)	796,000

TRS03ILCX

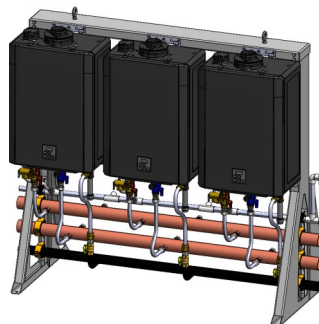

PROJECT NOTES

CONTACT INFORMATION

Rinnai Commercial Water Heating Services

800-621-9419

commercialservices@rinnai.us

